



ATLANTIC WINDLASS SERIES

Owner Manual for 600 & 900 Models

Horizontal Windlasses

Single Gypsy for Chain or
Rope-and-Chain Combination

- FO3930 (600 Watts)
- FO3442 (900 Watts)

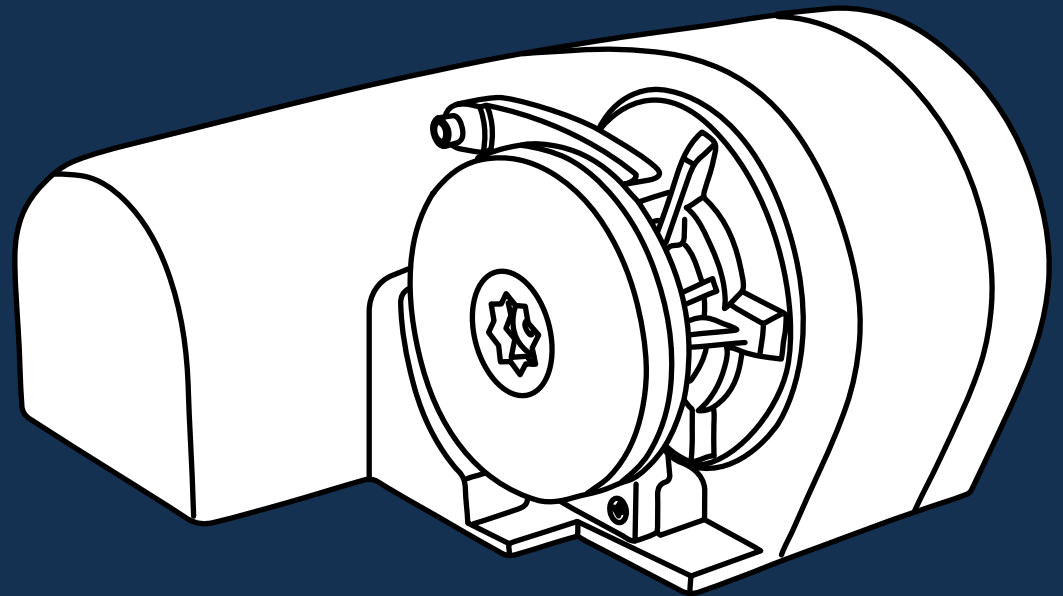

INDEX

- 01. Introduction
- 02. General Description
- 03. Key Features
- 04. Package Includes
- 05. Important Safety Warning
- 06. Technical Data
- 07. Gypsy & Rode Options (Rope/Chain Compatibility)
- 08. Dimensional Drawings
- 09. Installation Guide
 - 9.1. Location
 - 9.2. Basic requirements for installation
 - 9.3. Mounting Process
 - 9.4. Atlantic 600 & 900 Models Electrical Wiring Diagram

- 10. Operating Instructions
 - 10.1. Anchoring (Deploying the Anchor)
 - 10.2. Weighing Anchor (Retrieving the Anchor)
 - 10.3. Recommendations for Effective Anchoring
- 11. Maintenance
- 12. Exploded-View Drawing
- 13. Troubleshooting
- 14. Warranty
 - 14.1. One-Year Limited Warranty
 - 14.2. Warranty Exclusions
 - 14.3. How to Obtain Warranty Service
 - 14.4. Limitation of Liability

1. INTRODUCTION

Thank you for purchasing the Atlantic Windlass Series. Our company is committed to engineering anchoring systems that not only satisfy rigorous performance and safety requirements but are also designed with a style and finish that enhances the aesthetic profile of your vessel.

2. GENERAL DESCRIPTION

The Atlantic Series is a heavy-duty windlass designed for nautical use. The housing is constructed from High-Polished 316 Stainless Steel, offering a powerful and compact above-deck solution built for the rigorous conditions of the sea. It works with a chain only or a rope/chain combination.

3. KEY FEATURES

- **High-Speed Operation**
Part of the high-speed series of windlass models.
- **Durable Construction**
Full 316 stainless steel housing with a mirror-polished finish.
- **Powerful & Compact**
Designed for maximum power in a compact footprint.
- **Flexible Installation**
Ideal for horizontal mounting, especially on thick decks or where under-deck space is minimal.
- **Adjustable Clutch**
Allows for precise control during operation.
- **Versatile Gypsy**
Supports either chain-only or a rope/chain combination.

4. PACKAGE INCLUDES

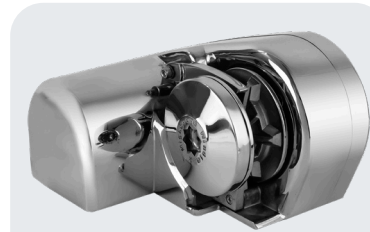

Horizontal Windlass



Control Box
(4-Wire Solenoid)

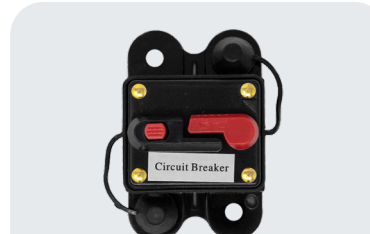

Amps Circuit Breaker



Foot Switch



Rocker Switch



Clutch Handle



Mounting Template

5. IMPORTANT SAFETY WARNINGS

→ Intended Use

Windlasses are designed to deploy and retrieve anchors. DO NOT use this equipment for other purposes, such as towing, mooring, or lifting personnel.

→ Secure the Rode

Always secure the anchor rode (chain/rope) to a cleat, bollard, or chain stopper when anchored or underway. The windlass is not designed to withstand the static loads of an anchored vessel.

→ Operational Hazard

Keep hands, feet, hair, and loose clothing clear of the windlass, gypsy, and anchor rode while it is operating.

→ Supervision



Do not operate the windlass without a clear line of sight to the unit and the anchor.

→ Electrical System

Disconnect power to the windlass at the main breaker or isolator switch when not in use, especially while underway or when performing maintenance.

6. TECHNICAL DATA



The following table details the key technical specifications for the FO3930 and FO3442 models. This data is essential for correct model selection, electrical planning, and ensuring system compatibility.

Parameter	 FO3930 Model Atlantic 600	 FO3442 Model Atlantic 900
	Motor (W)	600 Watts
Voltage (V)	12 V	12 V
Current Draw (A)	50 A	75 A
Max. Working Load	400 lbs 180 kg	550 lbs 250 kg
Max. Power Pull	1200 lbs 540 kg	1650 lbs 750 kg
Drop Speed	35 m/min 115 ft/min	35 m/min 115 ft/min
Retrieval Speed	26 m/min 85 ft/min	28 m/min 92 ft/min
Weight	28.7 lbs 13 kg	28.7 lbs 13 kg

7. GYPSY & RODE OPTIONS (ROPE/CHAIN COMPATIBILITY)

The Atlantic Series windlass offers flexibility by accommodating either chain-only or a rope/chain combination rode. While both are supported, we always recommend a chain-only configuration for optimal performance and reliability, provided your application allows for it.

Please refer to the table below for specific gypsy and rode compatibility.

Windlass Model	Chain Type		Rope Type
			
FO3930 Atlantic 600	7mm - 1/4"		3-Strand 1/2" (12mm)
	7mm	1/4"	
	DIN 766	HT G4	
FO3442 Atlantic 900	8mm - 5/16"		3-Strand 9/16" (14mm)
	8mm	5/16"	
	DIN 766	HT G4	

8. DIMENSIONAL DRAWINGS

Atlantic 600 & 900 Models Dimensions

Refer to the technical diagrams for precise measurements for installation.

A | 5-9/16 inches
(141 mm)

B | 10-1/16 inches
(256 mm)

C | 7-15/16 inches
(201 mm)

D | 4-3/4 inches
(120 mm)

E | 2-1/4 inches
(57 mm)

F | 5-1/2 inches
(139 mm)

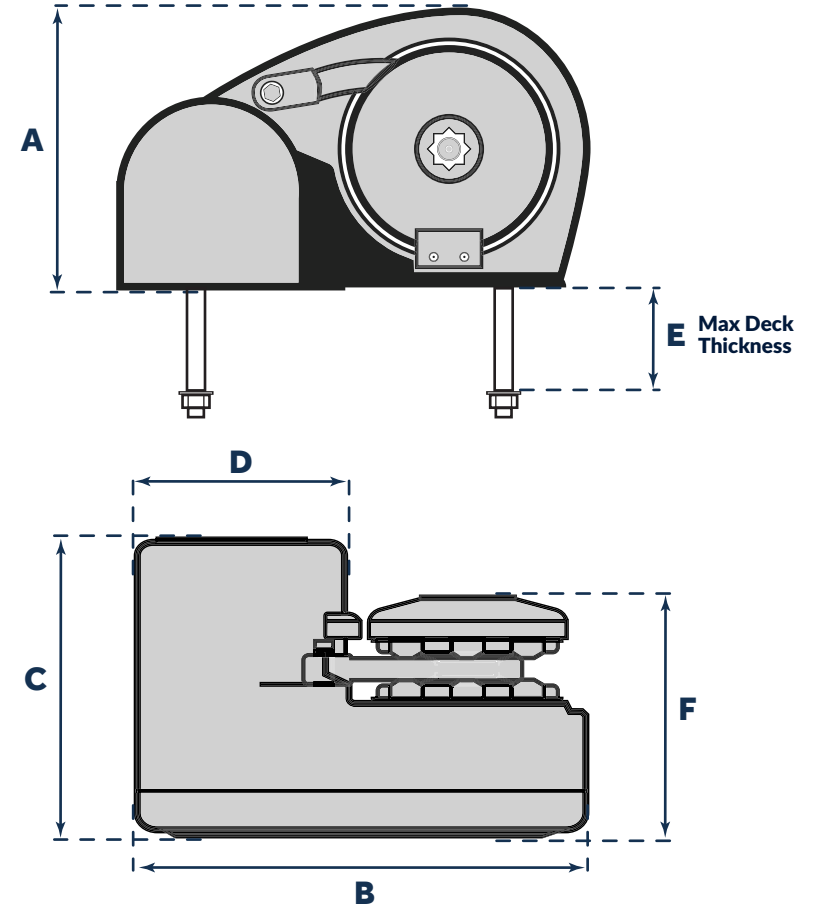

9. INSTALLATION GUIDE

The Atlantic Series is specially designed for boats with limited space underneath the deck. It features an easy horizontal installation, an adjustable clutch, and is compatible with both chain-only or rope/chain combination rodes.

Atlantic 600 & 900 Models Application:

→ Suitable for boats from 20 ft to 45 ft, depending on the vessel's design and displacement.

Improper installation remains the most common cause of windlass failure. Therefore, installation of the Five Oceans windlass must be performed by a qualified marine technician to ensure safety and reliability.

9.1. LOCATION

→ Alignment

The windlass must be installed so that the anchor rode (chain/rope) runs horizontally from the gypsy to the bow roller.

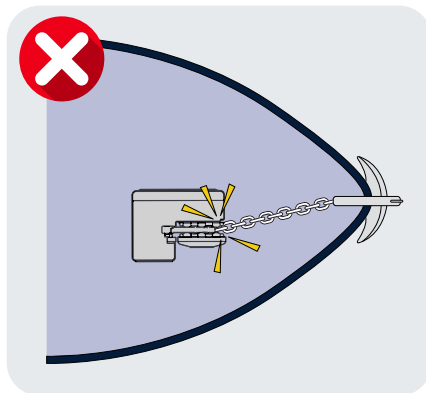
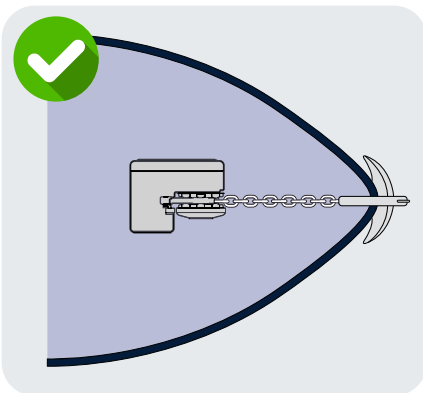

→ Anchor Locker Fall

There must be enough vertical space in the anchor locker for the rode to fall freely. This prevents the rode from piling up and jamming the windlass.

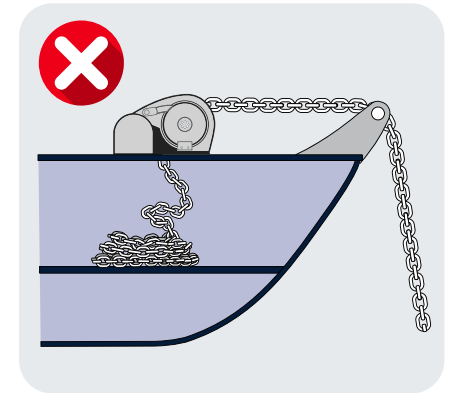
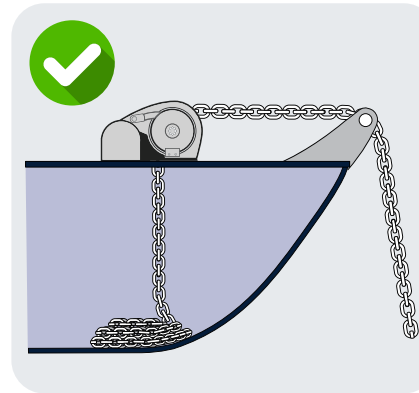

→ Deck Surface

The deck must be flat and strong enough to support the maximum pull loads of the windlass. Ensure that the upper and lower surfaces of the deck are as parallel as possible. If this is not the case, compensate for the difference appropriately.

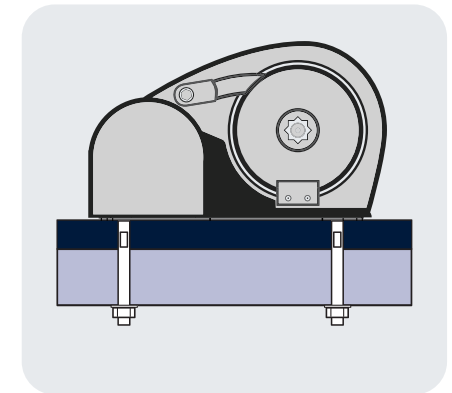
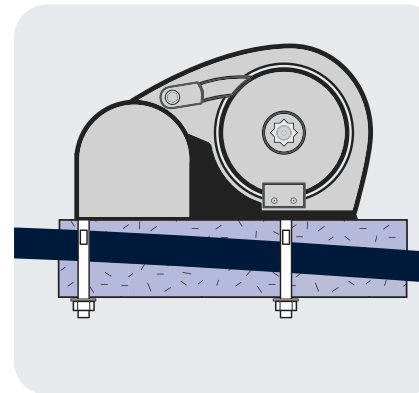

9.2. BASIC REQUIREMENTS FOR INSTALLATION

- High-Quality Marine Sealant
- Electric Drill with Bit
- Hex Wrench

9.3. MOUNTING PROCESS

→ Template

Use the mounting template provided to mark the position of the mounting bolt holes and the pass-through hole for the anchor rode.

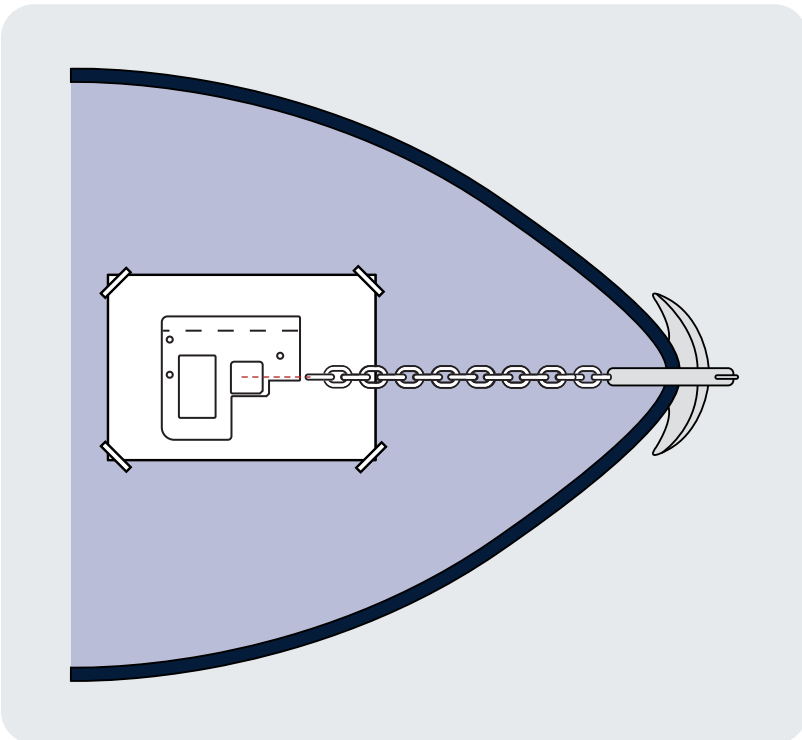

→ Inspection

Before drilling, check for obstructions beneath the deck (wires, bulkheads).

→ Drilling

Drill the holes according to the template specifications.

→ Sealing

Apply a high-quality marine-grade sealant generously to the base of the windlass and around the bolt holes before fastening. This is critical to prevent water intrusion into the deck core.

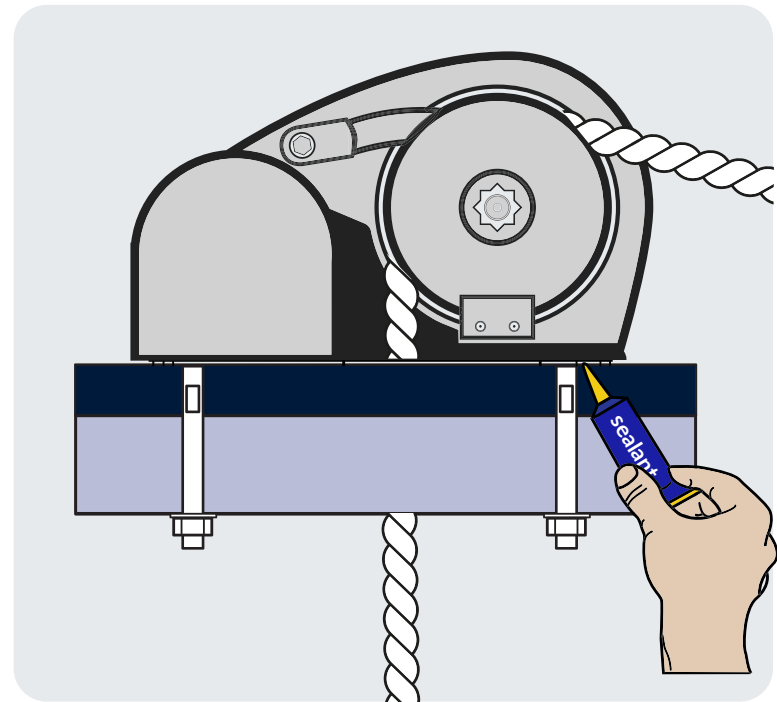

→ Fastening

Tighten the nuts and washers on the bolts evenly.

9.4. ELECTRICAL WIRING DIAGRAM

To ensure operational safety and full compliance with marine standards, Five Oceans strongly recommends that the Atlantic windlass series be professionally installed. All electrical wiring, in particular, must be completed by a qualified marine technician.

The cable table provides recommended cable sizes based on the total cable length required from the battery, following the cable routes. It is essential that the anchor windlass be wired with cables of sufficient gauge, as suggested in the table below:

Please do not confuse cable length with the length of the vessel.

For optimal performance and safety, adhere to the following electrical installation guidelines:

→ Circuit Breaker

The included circuit breaker must be installed in a dry, readily accessible location close to the battery. In the event of an overload, the breaker will trip; it must be manually reset to restore power to the windlass.

→ Wiring and Voltage Drop

The performance of your windlass is directly dependent on the correct cable size relative to the length of the wiring run. To ensure the motor receives adequate power, the total voltage drop over the complete wiring circuit must not exceed 10%.

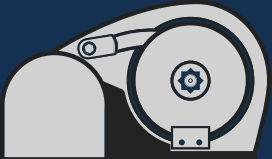
 Windlass Model	Wire Gauge Selection		Circuit Breaker	Switches	
	Determining the appropriate wire gauge based on the electrical load and the length between the battery, solenoid, and motor, to ensure minimal voltage drop and compliance with marine wiring standards.			Fuse	Wire Gauge
	Battery-to-Solenoid or Solenoid-to-Motor Length of Cable Run				
	Up to 24 Ft (8 M)	Up to 50 Ft (15 M)			
FO3930 Atlantic 600 Motor: 600W - 12VDC	16 mm ² 6 AWG	25 mm ² 4 AWG	60 Amps	5 Amps	2.5 mm ² 14 AWG
FO3442 Atlantic 900 Motor: 900W - 12VDC	25 mm ² 4 AWG	35 mm ² 2 AWG	80 Amps	5 Amps	2.5 mm ² 14 AWG

Atlantic 600 & 900 Electrical Wiring Diagram (2-Wire Motor)

The following diagram details the complete electrical circuit for the windlass installation. Ensure all cable gauges and connection points match this schematic to prevent system failure or electrical hazards.

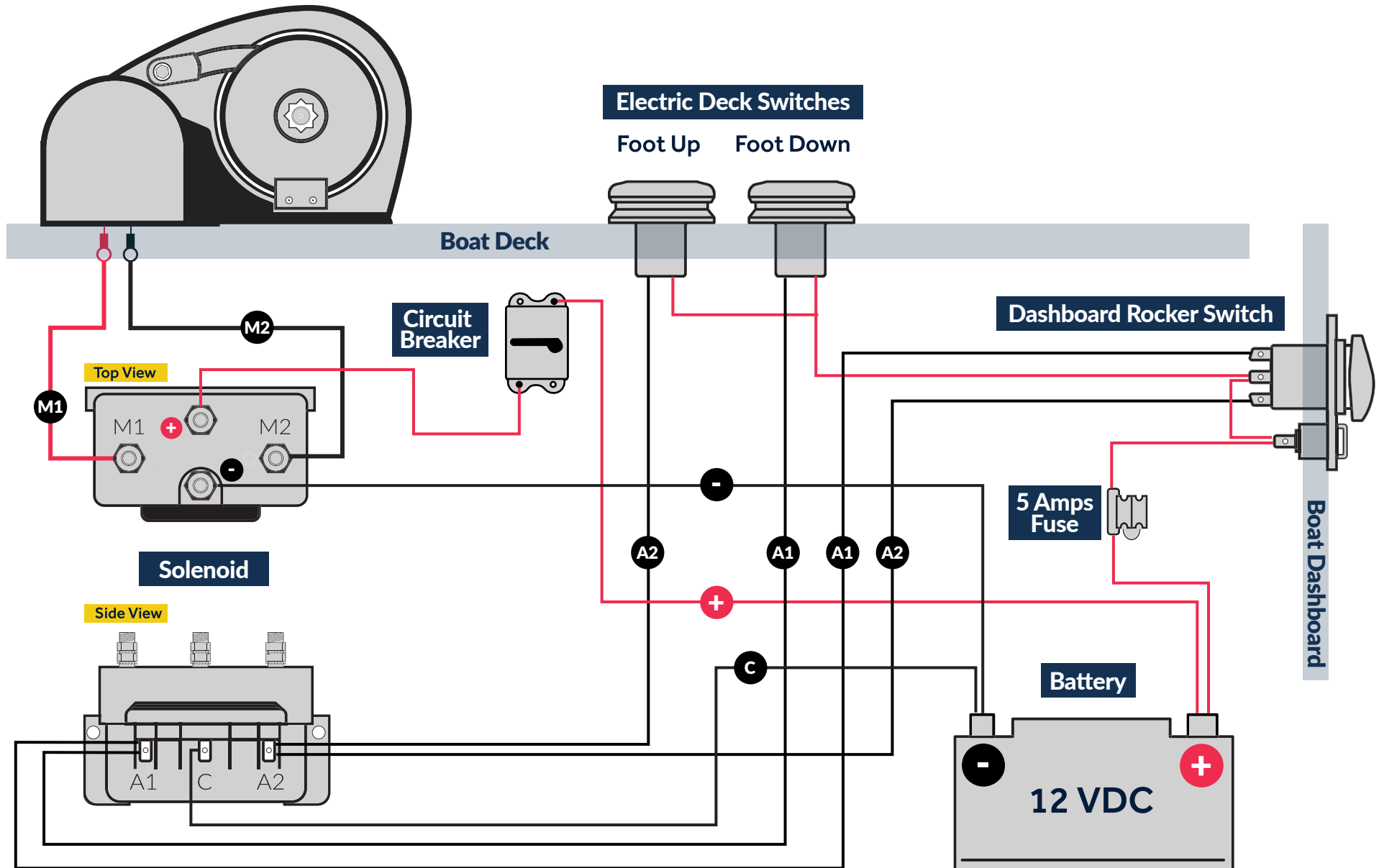

10. OPERATING INSTRUCTIONS

10.1. ANCHORING (DEPLOYING THE ANCHOR)

1. Start the vessel's engine. This ensures the battery is charging and can handle the windlass load.
2. Engage the windlass main breaker.
3. Release the chain stopper or remove the rode from the cleat.
4. Press the "DOWN" switch.
5. Once the desired length of rode (scope) is out, stop the windlass.
6. **IMPORTANT!** Secure the chain/rope to a chain stopper or cleat. Do not leave the vessel's load pulling directly on the windlass.
7. Disengage the main breaker.

10.2. WEIGHING ANCHOR (RETRIEVING THE ANCHOR)

1. Start the vessel's engine.
2. Engage the main breaker.
3. Press the "UP" switch.

4. If the anchor is stuck, do not use the windlass to pull the boat free. Slowly motor the boat forward using the engine to take the strain off the rode while retrieving the line. The windlass is designed to lift the anchor, not to pull the boat.
5. Once the anchor is secured in the bow roller, secure the chain/rope firmly.
6. Disengage the main breaker.

10.3. RECOMMENDATIONS FOR EFFECTIVE ANCHORING

1. For a secure anchorage, maintaining proper catenary is essential, as it ensures that the load on the anchor is applied as close to horizontal as possible. Correct catenary is achieved by deploying a length of chain, or a chain/rope rode 5 to 10 times the water depth.

Apply the correct scope ratio:

→ 5:1 (Calm)

For short stops in very calm weather.
15 ft depth x 5 = 75 ft of rode.

→ 7:1 (Standard)

The recommended minimum for most conditions and for anchoring overnight.
15 ft depth x 7 = 105 ft of rode.

→ 10:1 (Heavy Weather)

For strong winds or rough seas.
15 ft depth x 10 = 150 ft of rode.

Rule: When in doubt, let more out. Too much scope is far safer than too little.

- 2. IMPORTANT!** Once deployed, secure the chain firmly to a cleat, bollard, or chain stopper. The windlass is not designed to take the load of the boat.
- 3.** Use your engine in a gentle reverse to "set" the anchor into the seabed.
- 4.** Use the boat's engine to gently motor forward and assist the windlass during anchor retrieval.

11. MAINTENANCE

Regular maintenance is vital for the longevity and safe function of your windlass.

→ **Rinse**

Wash the windlass and anchor rode with fresh water to remove salt deposits, which cause corrosion.

→ **Polish (Occasional)**

Clean the 316 stainless steel housing with a stainless-steel cleaner or polish to maintain its finish and prevent staining.

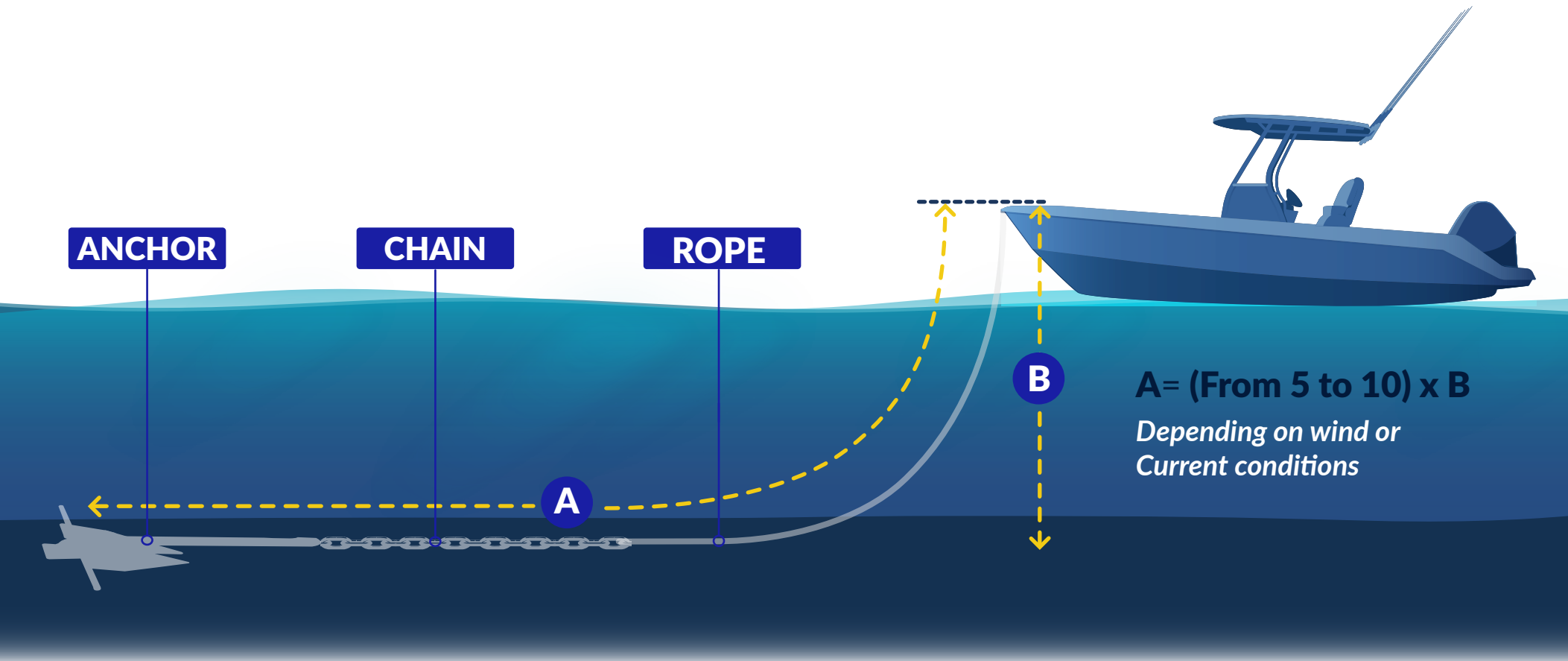

12. EXPLODED-VIEW DRAWING

The following exploded view diagram illustrates the windlass assembly and all its components. Please use this diagram and the accompanying parts list to accurately identify items for maintenance or when ordering replacements.

Part No.	Part Name	Quantity
1.	Hex Socket Screw	6
2.	Spring Washer	6
3.	Windlass Hausing A	1
4.	Hex Socket Screw	4
5.	Plain Washer	4
6.	Gearbox A	1
7.	3rd Grade Gear	1
8.	4th Grade Gear	1
9.	Shaft of 3rd Grade Gear	1
10.	Shaft of 2nd Grade Gear	1
11.	2nd Grade Gear	1
12.	Bearing	1
13.	Bearing	1
14.	Gearbox B	1
15.	Shaft of 4th Grade Gear	1
16.	Needle Roller Bearing	2
17.	Needle Roller Bearing	2
18.	Windlass Housing B	1
19.	Rope Fork	1
20.	Hex Socket Screw	2
21.	Spring Washer	2
22.	Cone Clutch	2
23.	Gypsy	1
24.	Gypsy Cap	1
25.	Plain Washer	1
26.	Pin-Spring	1
27.	Pressure Finger	1
28.	Spring	1
29.	Hex Socket	2
30.	Plain Washer	2
31.	1 st Grade Gear	1
32.	Motor	1
33.	Handle	1

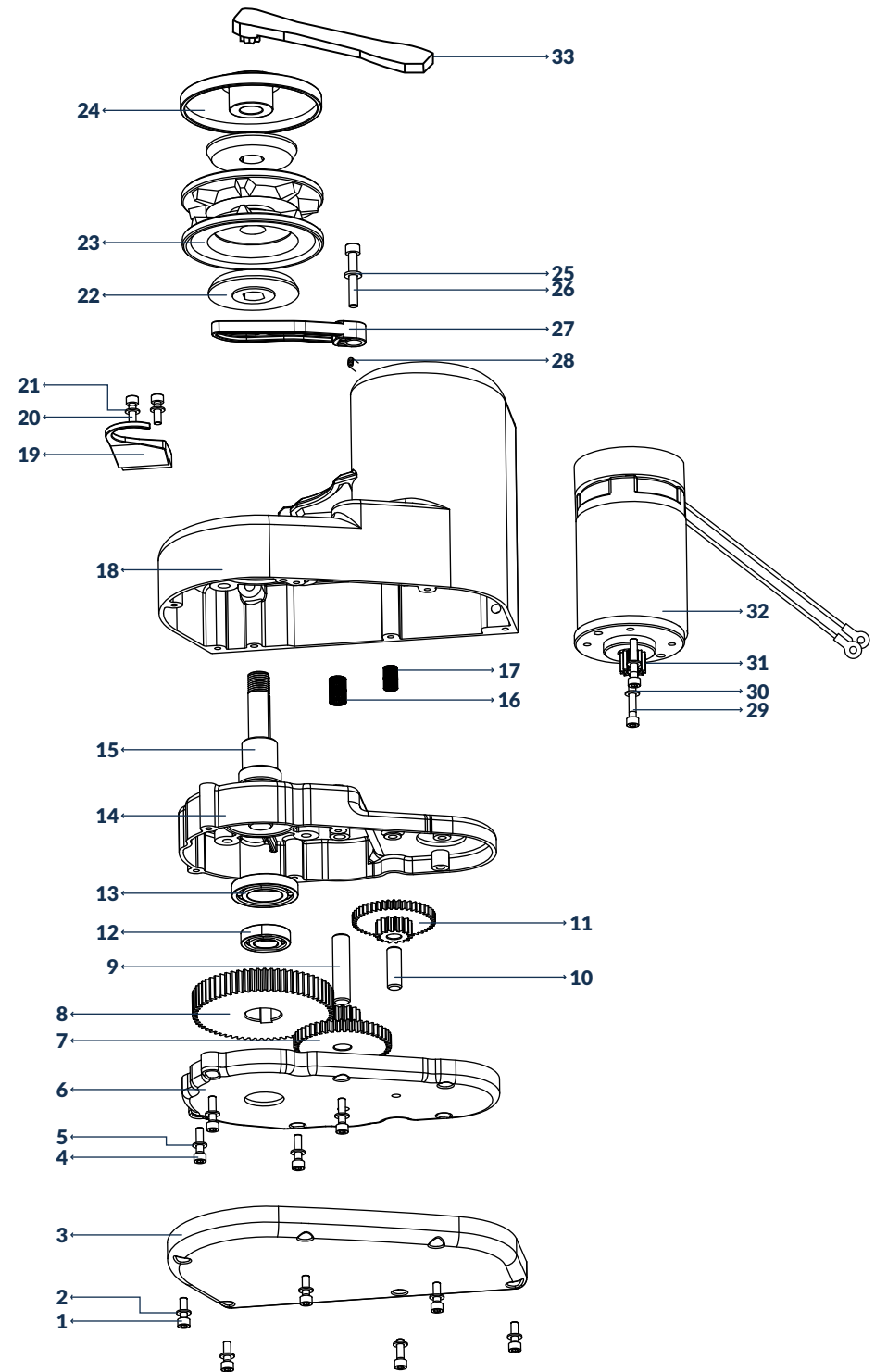

13. TROUBLESHOOTING

Important! Safety First

Before inspecting your windlass, turn off the main windlass circuit breaker at your boat's electrical panel. Windlasses draw very high currents and have powerful moving parts. If you are not comfortable, contact a specialist.

1. The Windlass Does Nothing (Completely Dead)

→ Check the Circuit Breaker

This is the most common cause. Find the main windlass breaker (usually near the batteries or on the main panel) and make sure it hasn't tripped. Reset it and try again.

→ Check the Controls

- **Foot Switches:** These often corrode. Press them firmly several times. If you can, check their connections underneath.
- **Helm Switch:** Ensure the switch at the helm is turned on.

→ Check the Solenoid (Contactor)

When you press the button (up or down), do you hear a loud "CLICK" coming from the solenoid/control box?

- If you hear a "CLICK" but the motor doesn't spin: The problem may be the motor itself or the heavy-gauge power connections between the solenoid and the motor.
- If you do NOT hear a "CLICK": The problem is likely the solenoid itself, or the low-voltage wiring running from your switches to the solenoid.

2. The Windlass Runs Slow or Seems Weak

→ Start Your Boat's Engine!

This is the #1 cause. A windlass uses a massive amount of power. Battery voltage will drop quickly if the engine isn't running and charging the batteries. Low voltage makes the windlass run slow and overheat.

→ Corroded or Loose Connections

Check the big, heavy-gauge battery cable connections (positive and negative). A single bad connection (with green rust or sulfation) creates high resistance and won't let enough power through. Clean and tighten them.

→ Old Batteries

Your batteries may no longer be able to supply the high current (amperage) the windlass demands.

3. The Motor Runs, but the Chain Doesn't Move (or Slips)

→ The Clutch is Loose

This is the most likely problem. The windlass is designed to slip if the clutch isn't tight. Use the windlass handle (winch handle) to tighten the top nut/cap on the gypsy (the part that grabs the chain). Tighten it clockwise.

→ For Rope Only

If you are using a rope/chain combination (rode), make sure the rope is the correct size and type (usually 3-strand) for your gypsy. Old, stiff rope will also slip.

4. The Chain/Rope Jumps or Jams in the Gypsy

→ Chain/Rope and Gypsy Mismatch

Did you recently replace your chain/rope? You must use the exact size and type of chain your gypsy is designed for. Chain/Rope sizes are not interchangeable.

→ Worn-Out Gypsy

If the windlass is old, the "teeth" on the gypsy may be rounded off and no longer grip the chain properly.

→ Chain/Rope Piling (Castling)

Check your anchor locker. If the chain is piling up in a "castle" directly under the windlass, it can't feed in freely and will jam. You need to help spread it out.

→ Mud or Debris

Clean the gypsy. Sometimes dried mud or a small rock can get jammed in it, preventing the chain from seating correctly.

→ Chain/Rope Conditions

The chain and rope must be in good working condition; if they are not, the windlass may not operate properly.

5. The Circuit Breaker Trips Constantly

→ Overloading

You are asking the windlass to do too much work

- Do not try to "pull" the boat to the anchor with the windlass. Use the boat's engine to motor forward slowly as you retrieve the chain.
- If the anchor is stuck, do not use the windlass to break it free. Cleat off the chain and use the boat's engine momentum to free it.

→ Low Voltage

As in Problem 2, if the voltage is low (boat engine off), the windlass will draw more amps to do the same amount of work, tripping the breaker. Always operate the windlass with the boat's main engine running.

→ Seized Motor or Short

If it trips immediately, there may be a mechanical problem (jammed gears) or an electrical short in the motor.

14. WARRANTY

14.1. ONE-YEAR LIMITED WARRANTY

Five Oceans Group LLC guarantees the original retail purchaser a one (1)-year warranty from the date of purchase for defects in materials or product construction.

During this period, Five Oceans Group LLC will, at its sole discretion, repair or replace any components that fail under normal use. Such repairs or replacement will be made at no charge to the customer for parts. The customer will be responsible for all associated shipping costs.

14.2. WARRANTY EXCLUSIONS

This Limited Warranty does not apply to or cover:

- Damage or failure resulting from improper installation, abuse, misuse, accident, or negligence.

- Failures caused by unauthorized alteration, modification, or repair.
- Normal wear and tear (e.g., cosmetic finishes, rust, or discoloration).
- Products used for non-marine applications.
- Damage caused by incorrect electrical wiring, improper voltage, or non-compliance with the installation guide.

14.3. HOW TO OBTAIN WARRANTY SERVICE

To obtain warranty service, the original purchaser must contact Five Oceans Group LLC. A copy of the original sales receipt is required as proof of purchase to validate the warranty. The product may need to be returned to our facility for inspection and repair.

14.4. LIMITATION OF LIABILITY

THIS WARRANTY IS EXCLUSIVE AND IS IN LIEU OF ALL OTHER WARRANTIES, WHETHER EXPRESS, IMPLIED, OR STATUTORY, INCLUDING ANY WARRANTY OF MERCHANTABILITY OR FITNESS FOR A PARTICULAR PURPOSE.

Five Oceans Group LLC's liability shall be limited to the repair or replacement of the product as stated herein. Five Oceans Group LLC shall not be liable for any incidental, consequential, special, or indirect damages, including but not limited to, loss of use, loss of revenue, or damage to the vessel or other property.

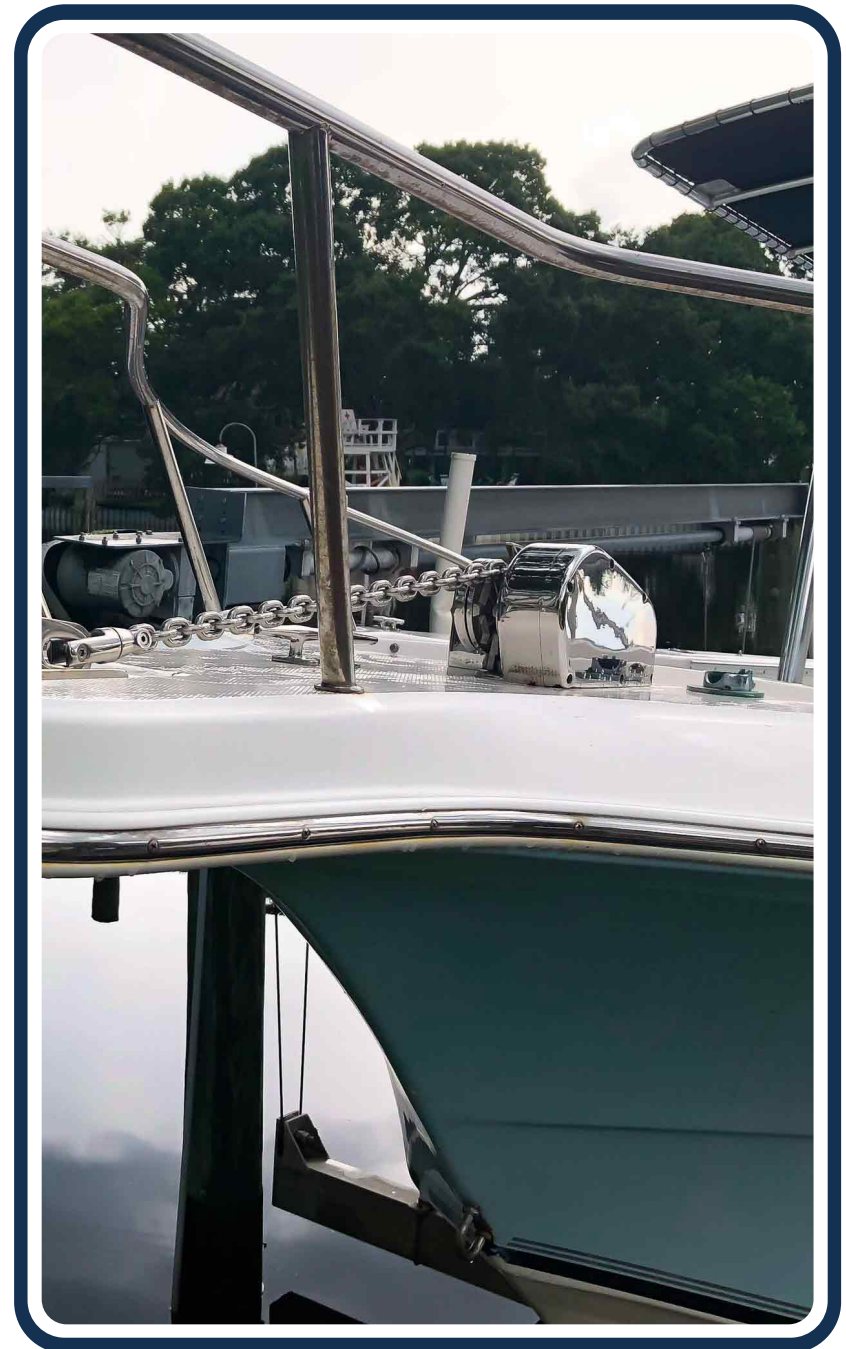



Five Oceans Group LLC

**Customer Support &
Technical Service**

www.five-oceans.com

info@five-oceans.com

© 2026 Five Oceans Group LLC. All rights reserved

ATLANTIC WINDLASS SERIES

Owner Manual for 600 & 900 Models

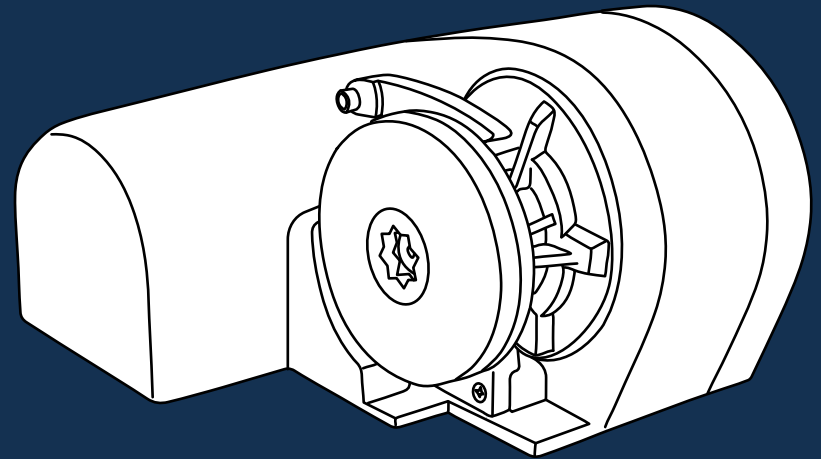

Horizontal Windlasses

→ FO3930 (600 Watts)

→ FO3442 (900 Watts)